







-  Sun path
-  Bus route
-  Current pedestrian route to tram stop
-  Tram route



- Large scale mass - stadium and offices
- Small scale mass - 2 storey residential

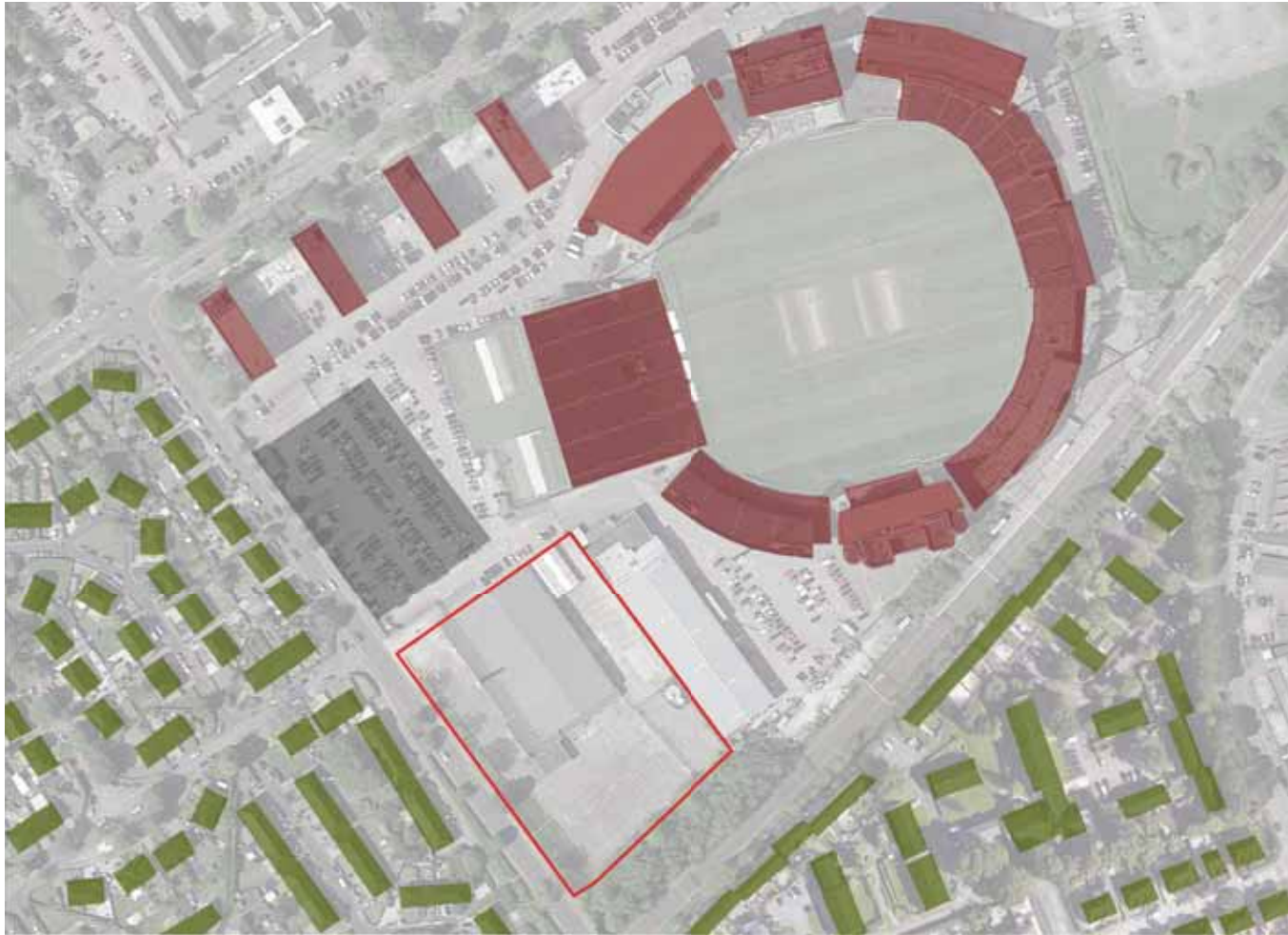
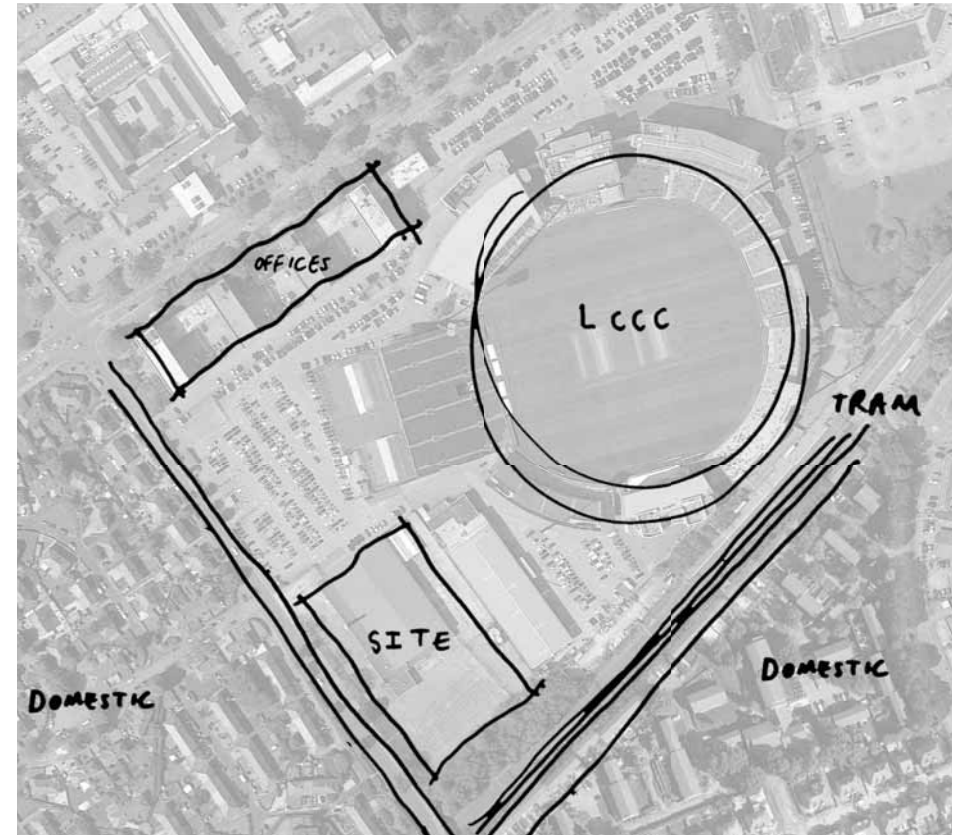

Immediate context - images



1.



2.



3.



4.



5.



6.

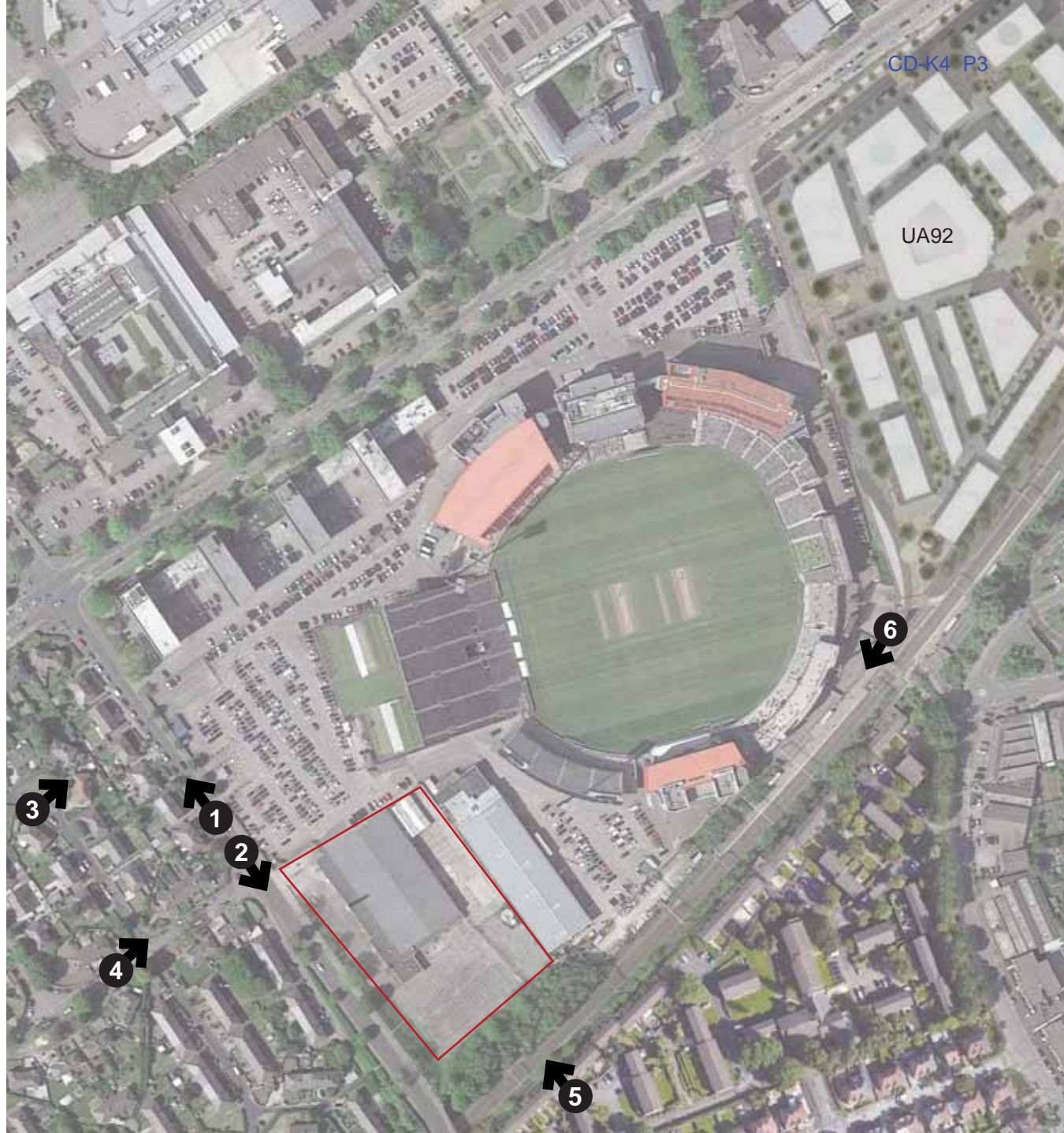

Wider context - images



1.



2.



3.

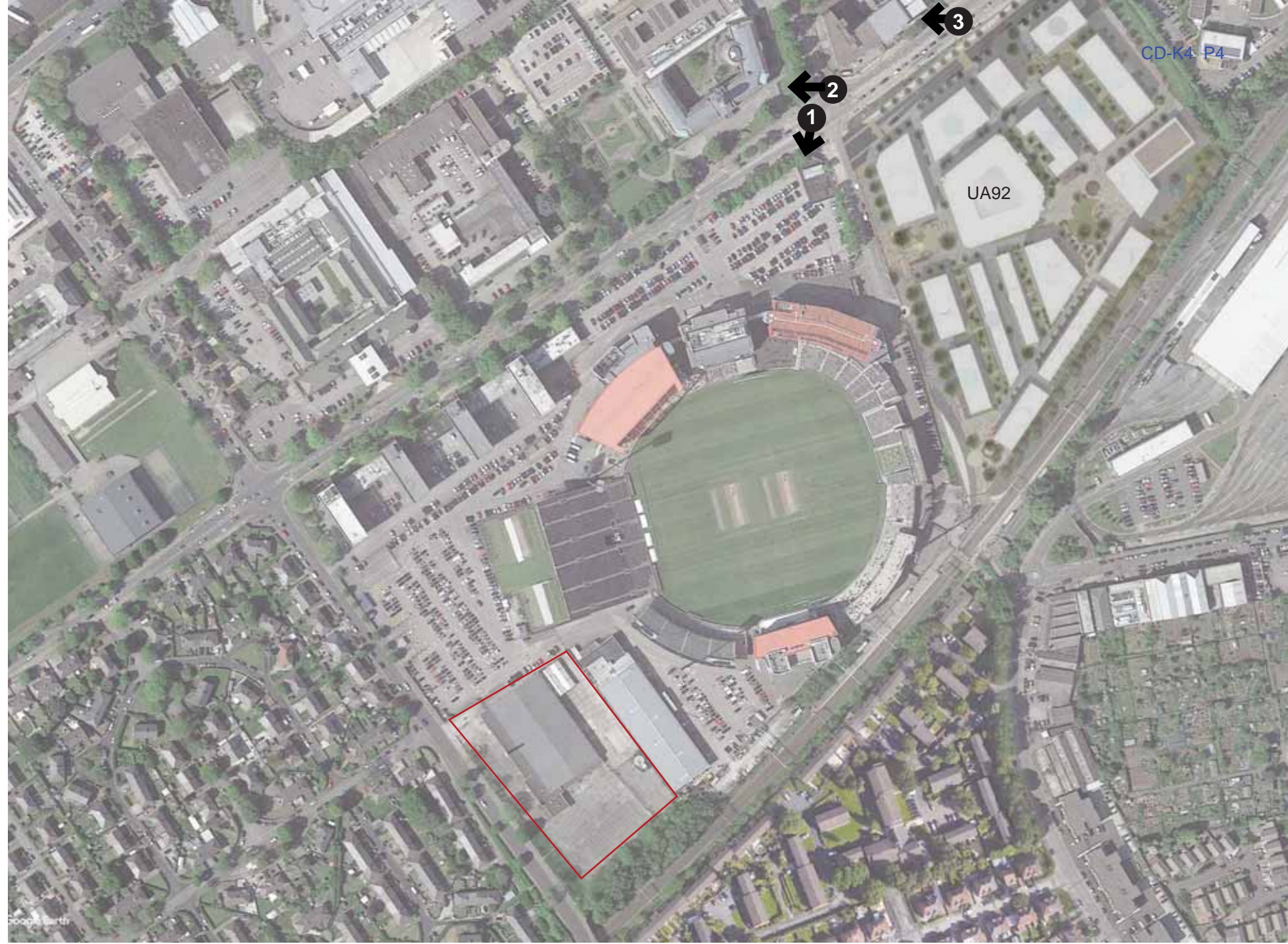



Site Levels



Level access point



level access

road rises



10m margin

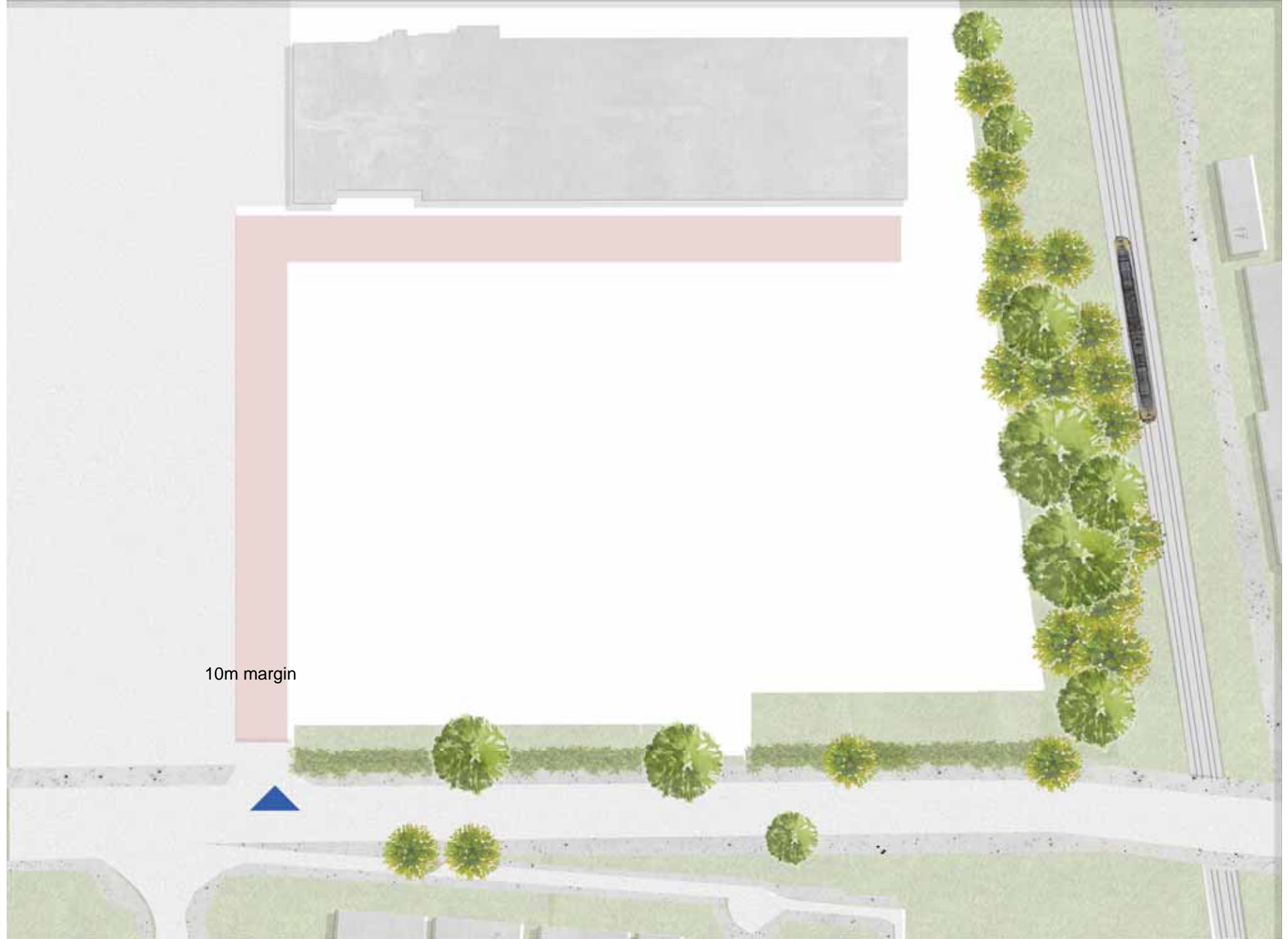

10m margin





proposed trees
define boundary

proposed trees
strengthen frontage





↑
ramp down

site reduced by 1.5m





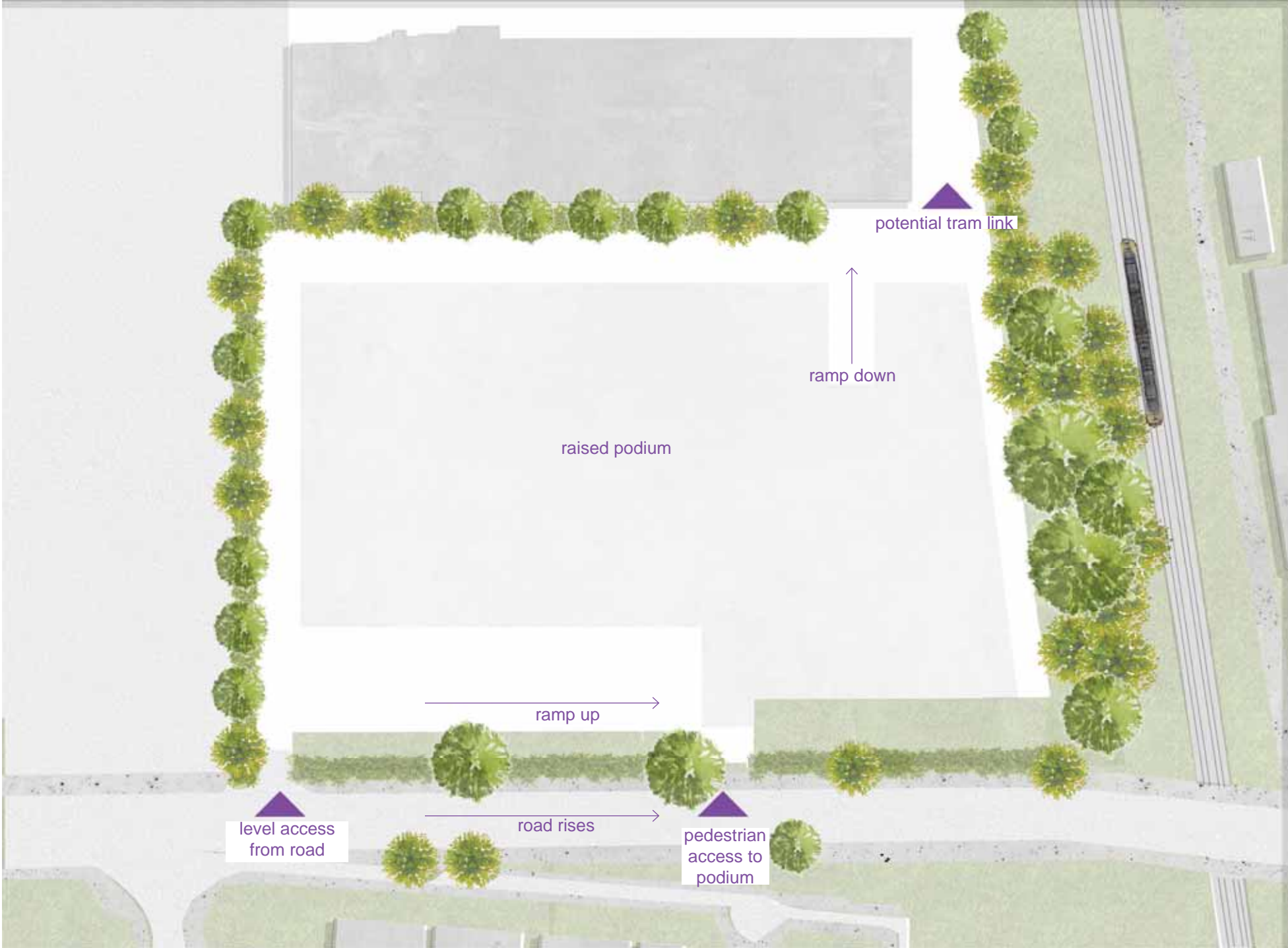

level access from road

pedestrian access to podium

potential tram link

ramp down

ramp up

road rises

raised podium



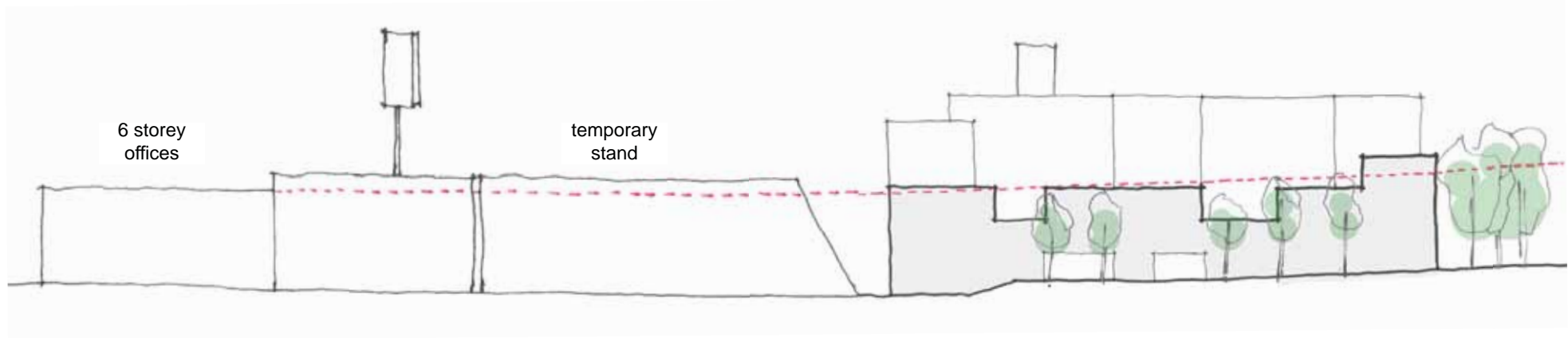
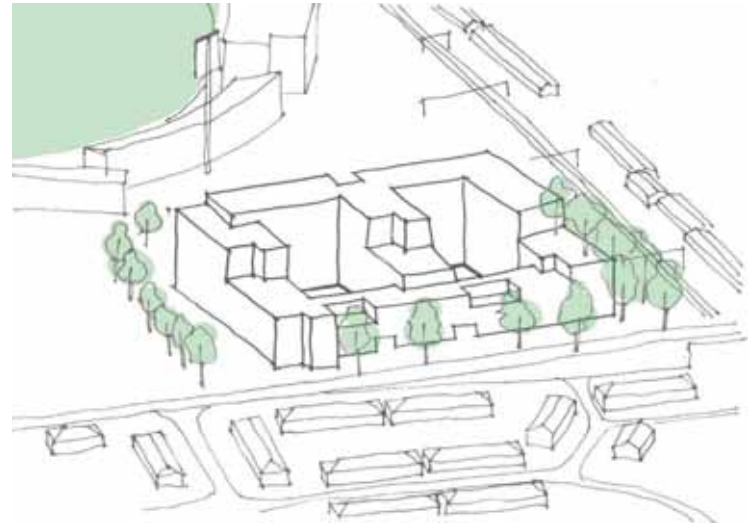
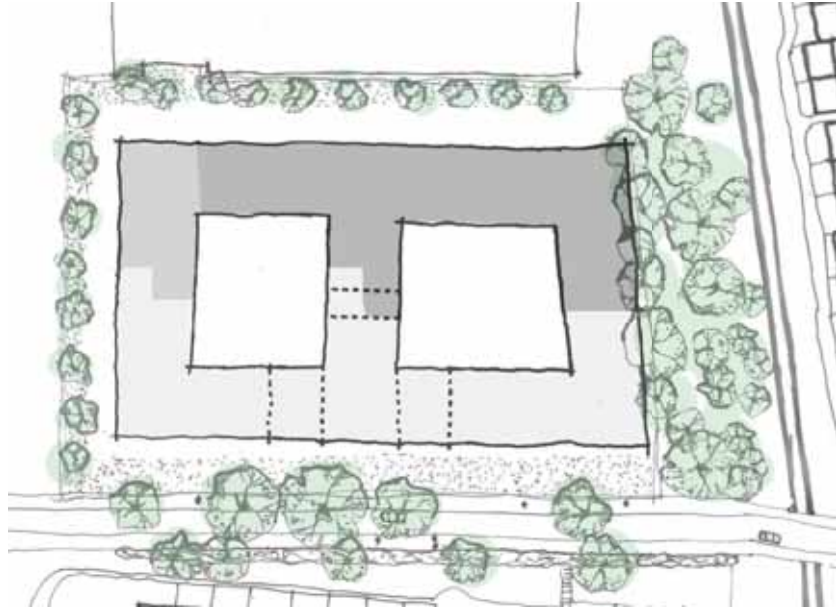

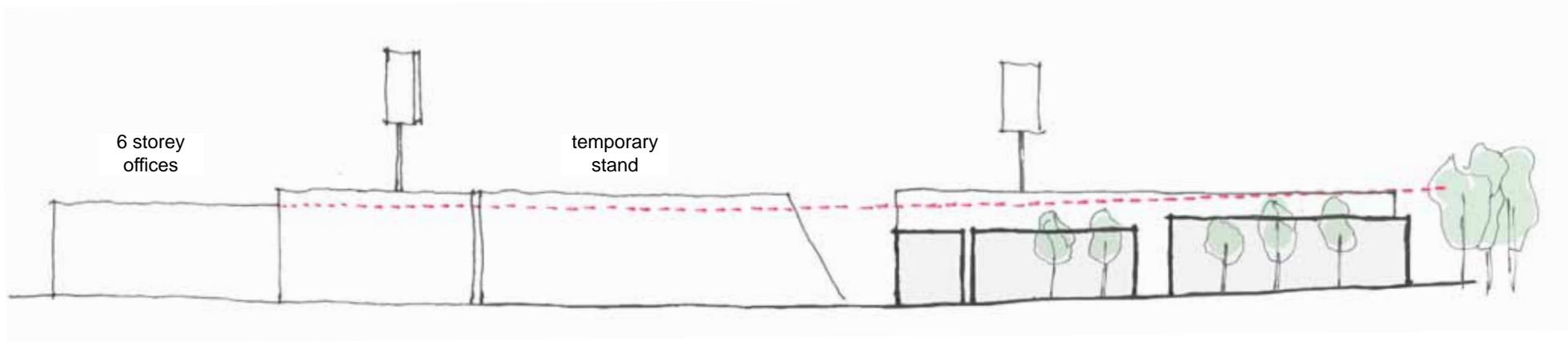
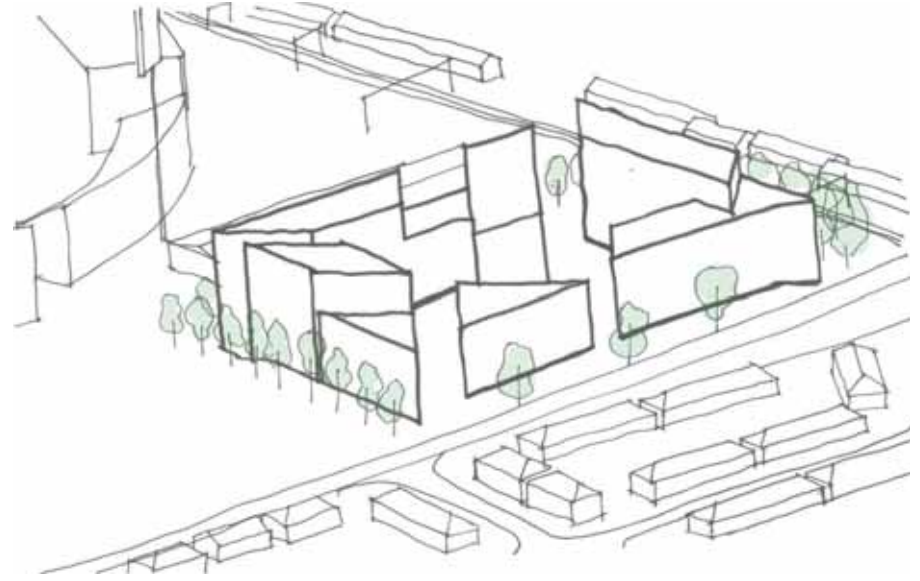
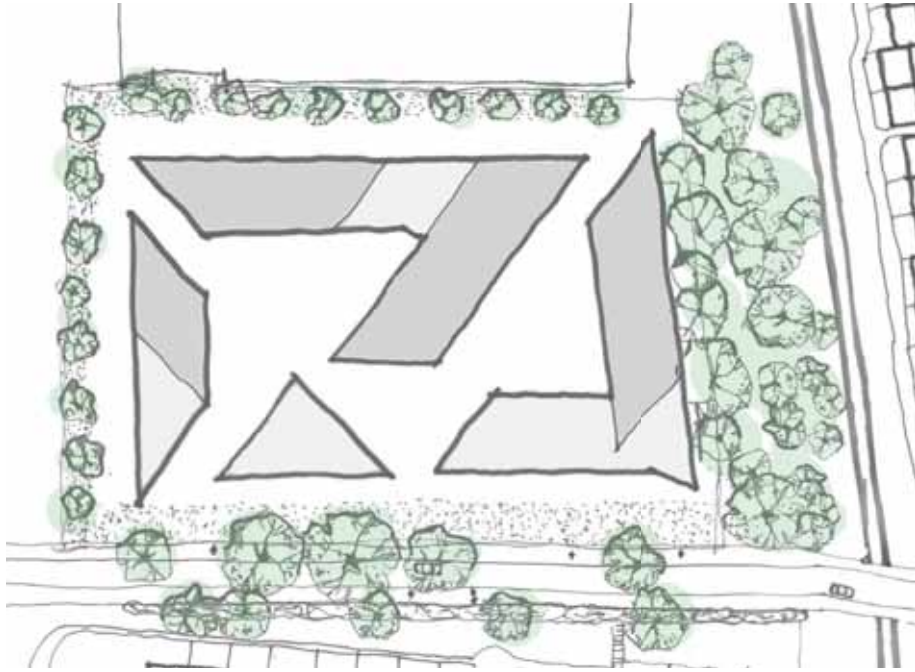

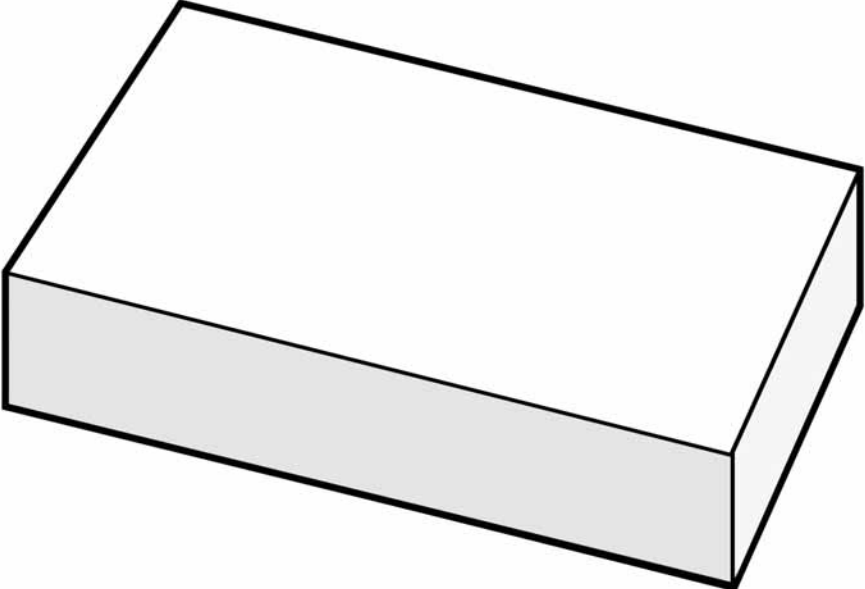

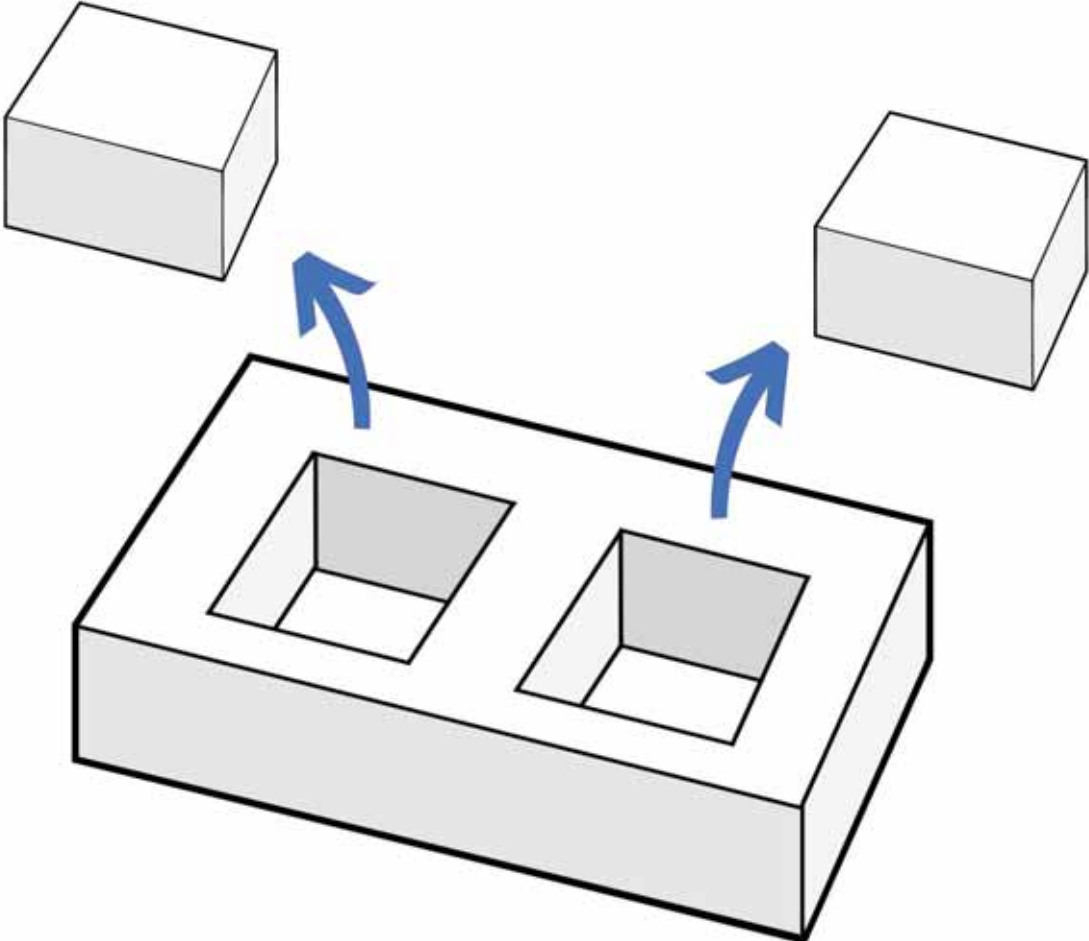

carve out courtyards

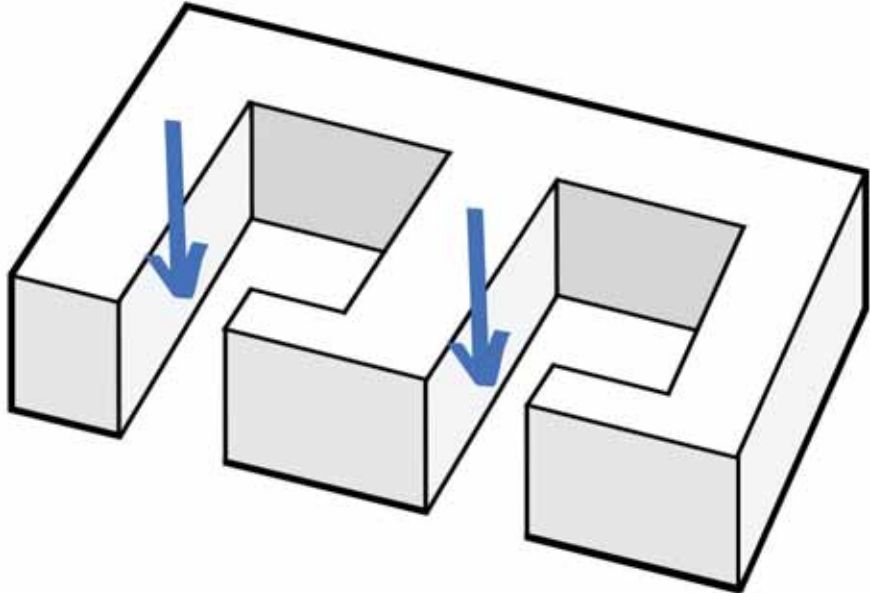

penetrate front elevation

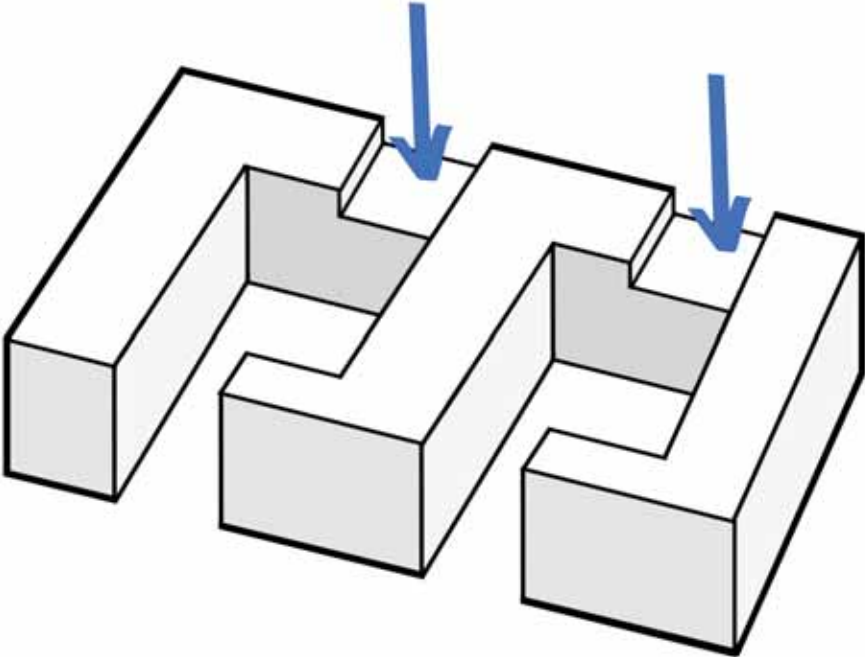

visual breaks to rear

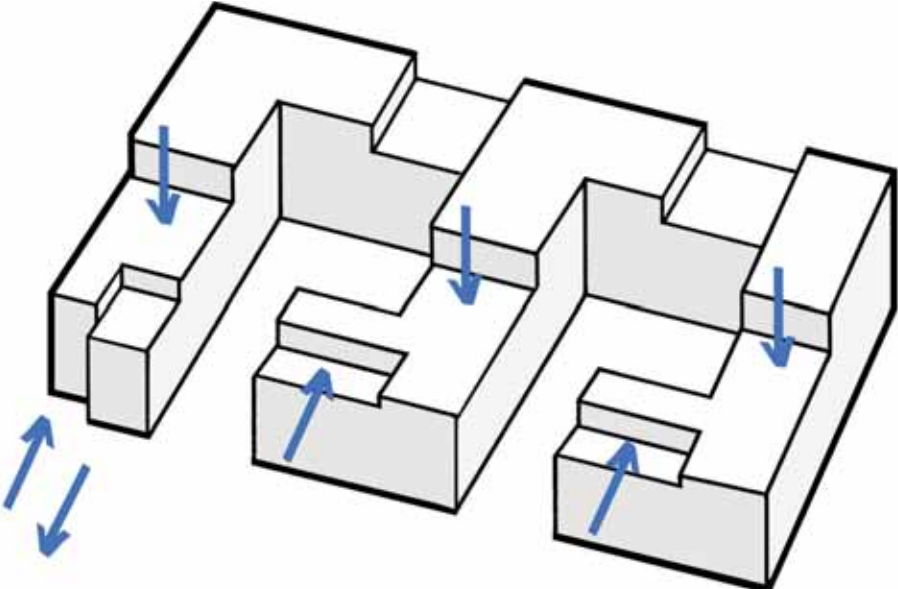

articulation

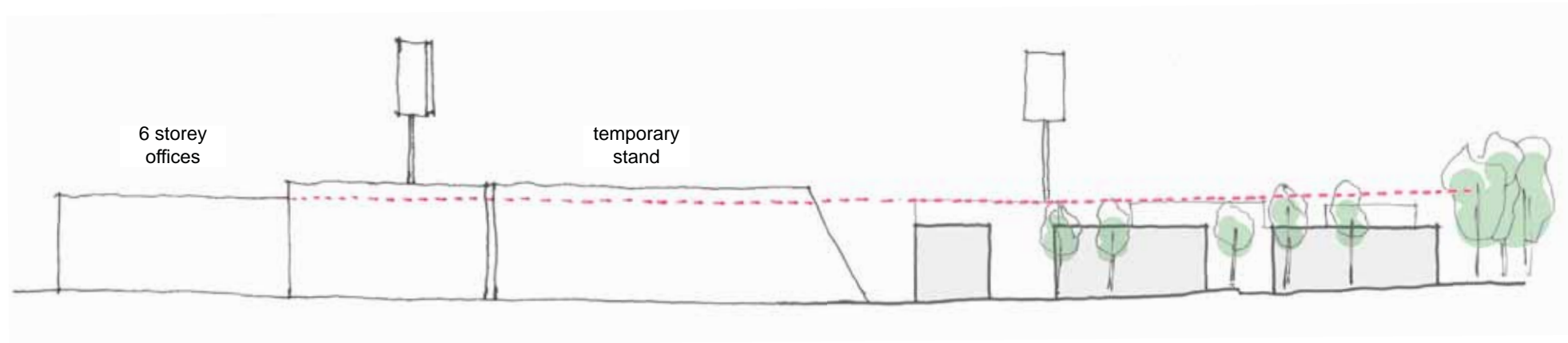
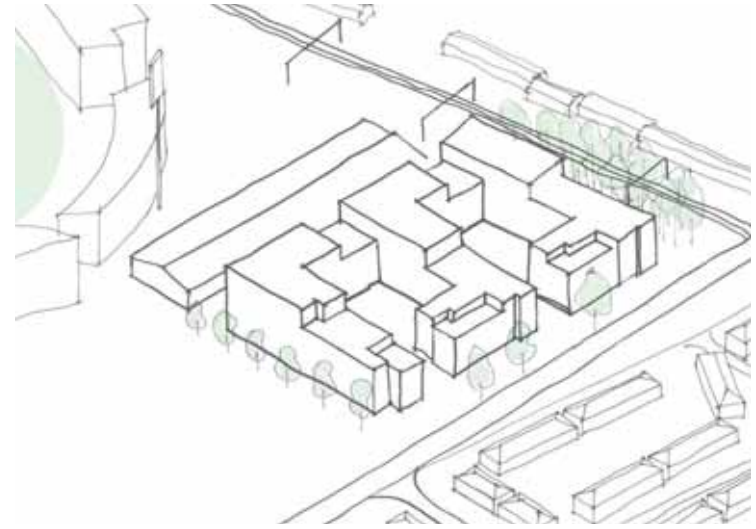
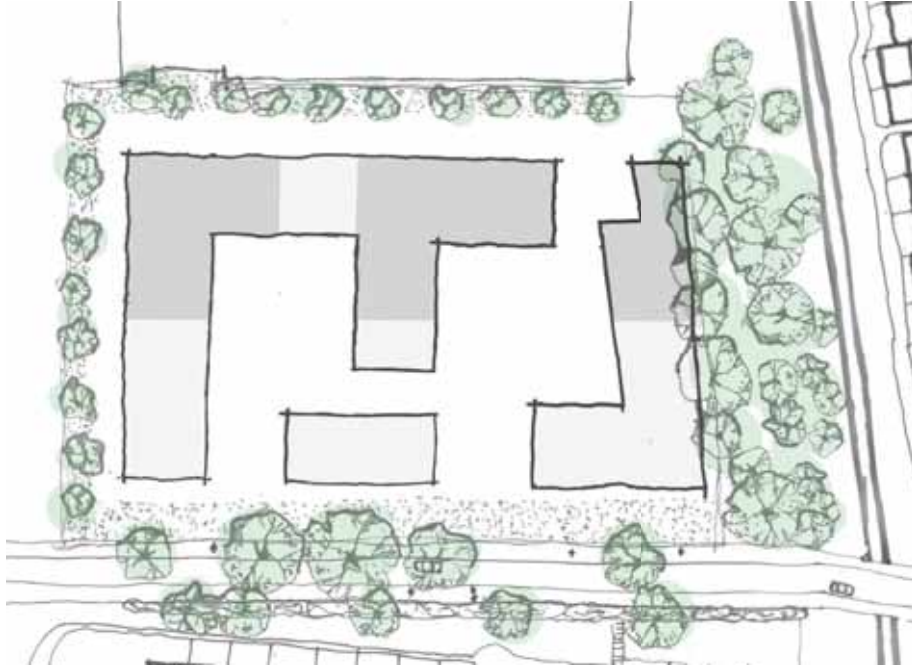

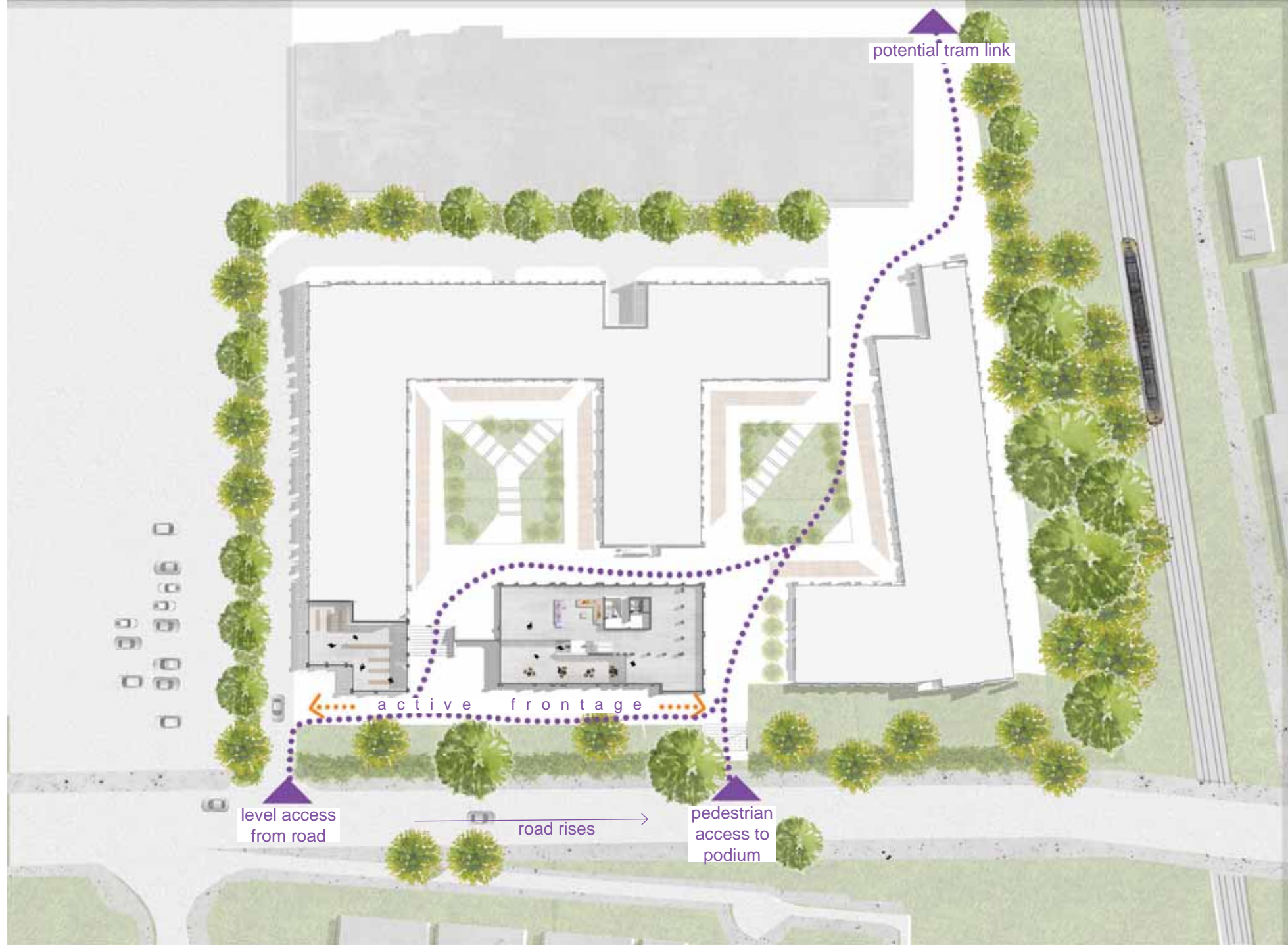

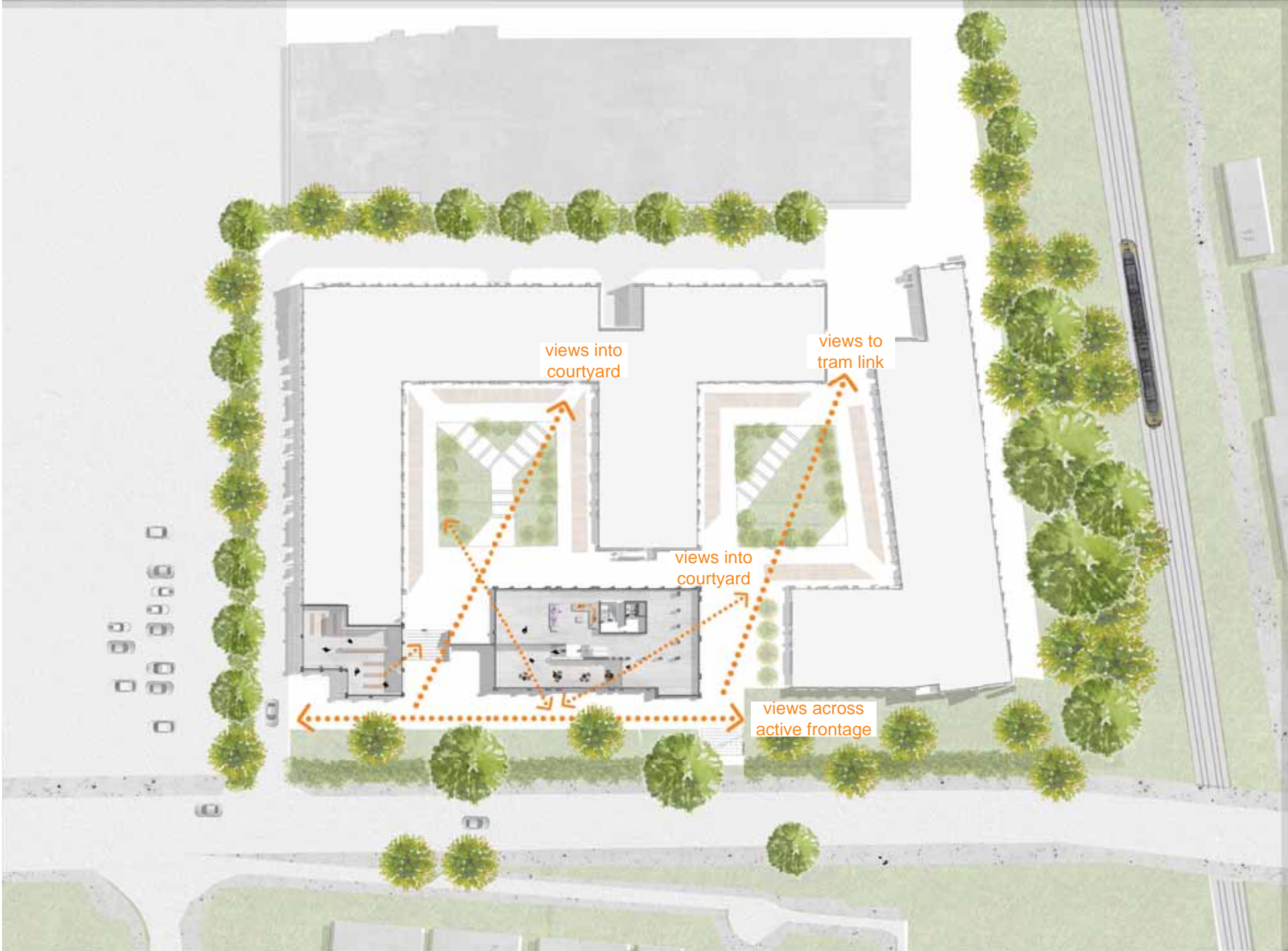







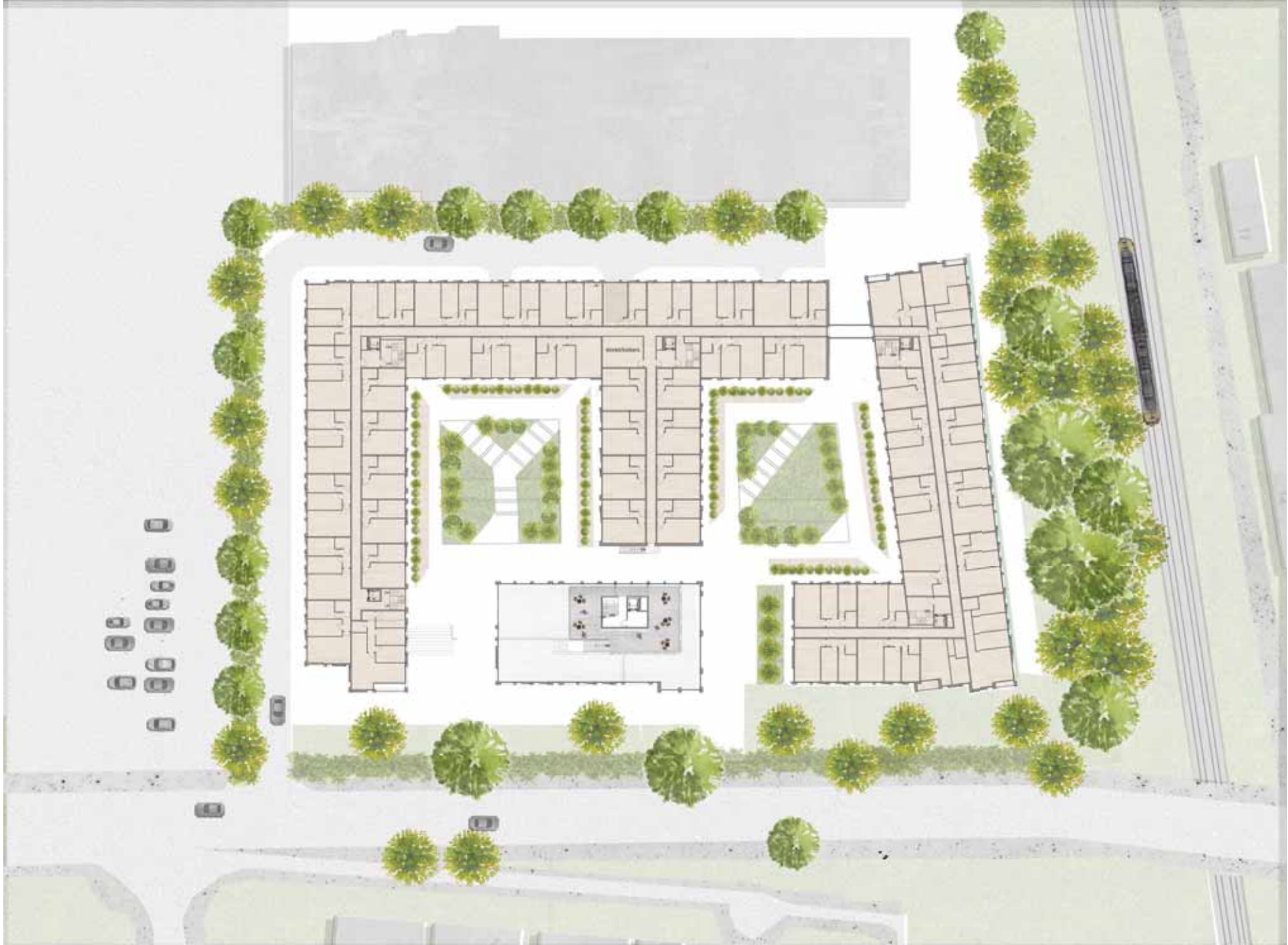









GREAT STONE ROAD



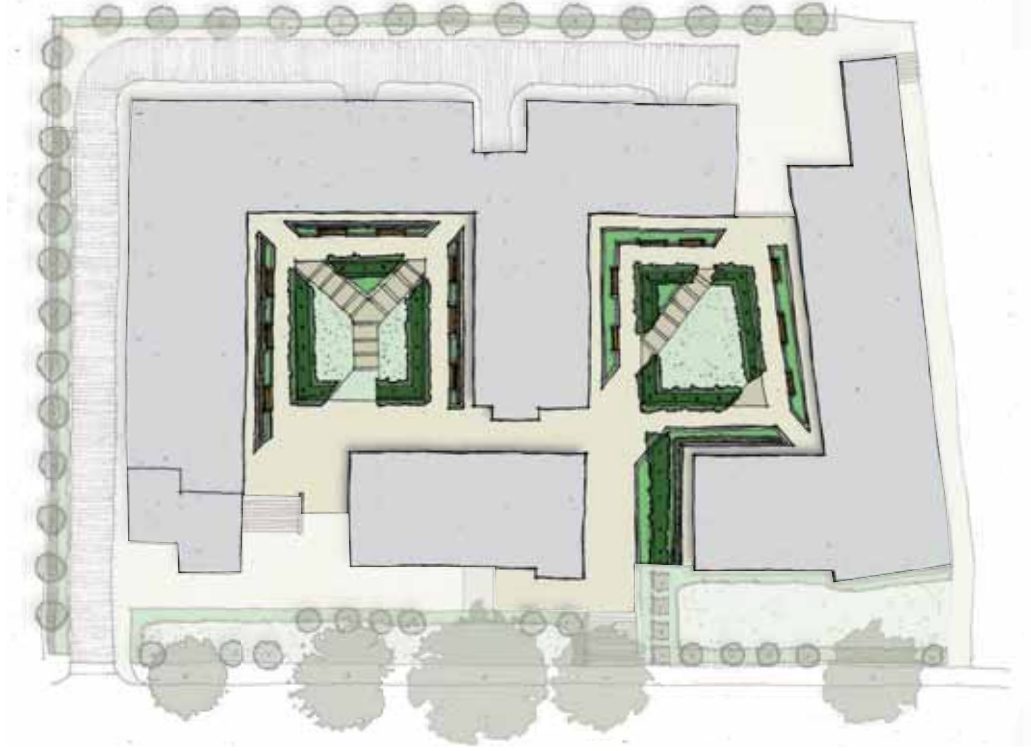

Side Elevation

CD-K4 P32

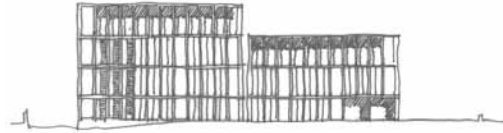
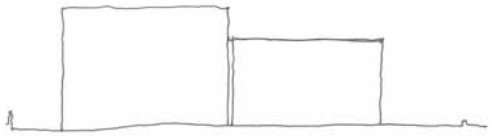



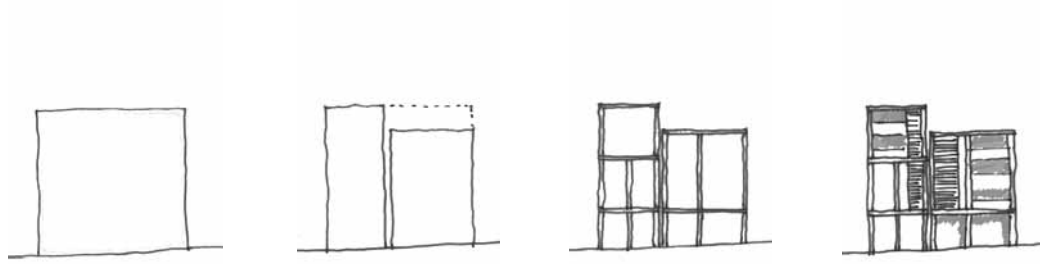

front elevation cgi







flythrough